

# Conductivity-Converter UNICON®-LF

Conductivity measurement with 2-and 4-electrode-cells

## Features

- Measuring range programmable from 0 ... 5.00  $\mu\text{S}/\text{cm}$  up to 0... 500 mS/cm (0 ... 0.500  $\mu\text{S}/\text{cm}$  up to 50.0  $\mu\text{S}/\text{cm}$  with ultra-pure water cell)
- Output 4 ... 20 mA, 2-wire system
- 2<sup>nd</sup> measuring range for conductivity, reversible by external signal
- Temperature compensation with RTD (Pt100 or Pt1000) sensor
- Monitoring of ultra-pure water acc. to USP<645>
- Output 4 ... 20 mA for temperature 2-wire system, measuring range programmable
- 2 alarm outputs, transistor, voltage free
- Isolation between input / output
- Simulation mode (manual operation) for conductivity and temperature
- Conductivity cell and connection cable are not included by delivery.

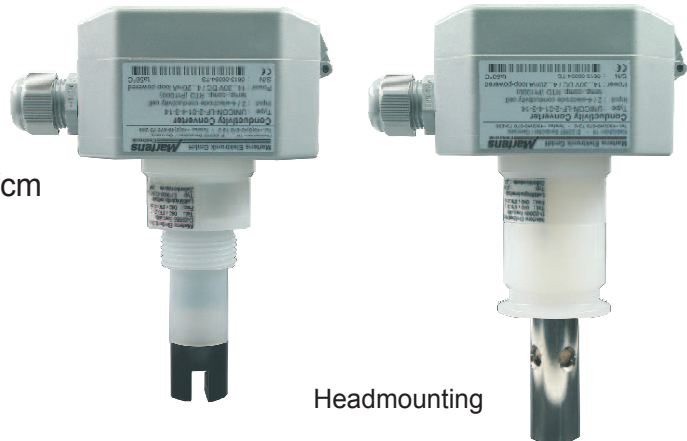

## General

The Conductivity converter UNICON-LF is suitable for measuring the conductivity characterising the purity or concentration of a liquid. Covering a wide range of application with only one conductivity cell is another advantage.

## Short information

Programming	Parameters are programmed via front side membrane keypad.
Alarm outputs	Switching performance for the alarm outputs is programmable as minimum or maximum function. States are displayed in the LCD Display.
USP monitoring	Devices including option 14 are programmable for monitoring of ultrapure water acc. to USP<645>. Setpoint settings of the alarm outputs are in accordance to the conductivity-temperature table (page 12). The switching performance is programmable for NC or NO contact.
USP calibration	Devices including option 14 have a special routine for USP calibration. Test-equipments in accordance to NIST are e.g. calibration solution EC23.8 and a precision thermometer type N63802.

---

---

## Technical data

### Supply voltage

Loop voltage	: 14 ... 30 V DC, 2-wire
Operating temperature	: -15 ... 55 °C (32 ... 122 °F)
Isolation	: conductivity output/temperature output/alarm output 1/ alarm output 2/measurement range switching
Test voltage	: 500 V DC
CE - conformity	: EN 50022, IEC61000-4-3/4/5

### Conductivity output

Unit	: µS/cm; mS/cm; kΩ/cm; MΩ/cm programmable
Decimals	: -"- 0 ... 3 decimals (depending on unit)
Measuring range	: -"- 500 ... 9999 digit (depending on unit and decimals)
Lowest / highest range	: 0 ... 5.00 µS/cm / 0 ... 500.0mS/cm; 0 ... 0.500µS/cm / 0 ... 50.0µS/cm with ultra-pure water cell
Temperature compensation	: non linear for ultra-pure water and natural water programmable from 0.000 ... 8.000 %/°C
Cell constant	: programmable from 0.080 ... 4.000
Standard error	: ± 0.5 % from measured value ± 2Digit
Temperature coefficient	: <100 ppm/°C
Measuring rate	: approx. 3/sec

### Temperature output

Output signal	: 4 ... 20mA
Burden	: $RA [\Omega] \leq \frac{\text{Supply voltage} - 14 \text{ V}}{0.02 \text{ A}}$
Temperature sensor	: RTD Pt100 or Pt1000 acc. to DIN IEC 751
Unit	: °C; °F programmable
Messbereich	: programmable from -40.0 ... +160.0 °C (-40.0 ... +320.0 °F)
min. / max. span	: 25.0 °C (45.0 °F)/200 °C (360.0 °F)
Standard error	: ± 0.1 % ± 1 Digit
Temperature coefficient	: <50 ppm/°C
Linearisation error	: ± 0.1 %

### Alarm output

Transistor	: 14 ... 30 V DC, max. 60 mA, short circuit protection
Voltage drop	: < 2V

### Measuring range change-over

Input resistance	: >10 KΩ
Range 1 active	: U = 0 ... 3 V DC
Range 2 active	: U = 12 ... 30 V DC

### Display

: LCD-dot matrix, 3.8 mm character height 2 lines 16 characters each
---

### Case

Design	: Head mounting or field mounting
Protection	: IP65
Material	: Polyamide with fibre glass PA6-GF 15/15
Weight	: 0.36 kg
Electrical connection	: screw terminal with pressure plate, 2.5 mm <sup>2</sup> fine wire, 4 mm <sup>2</sup> single wire
Front keyboard	: polyester

## Legend (open lid)

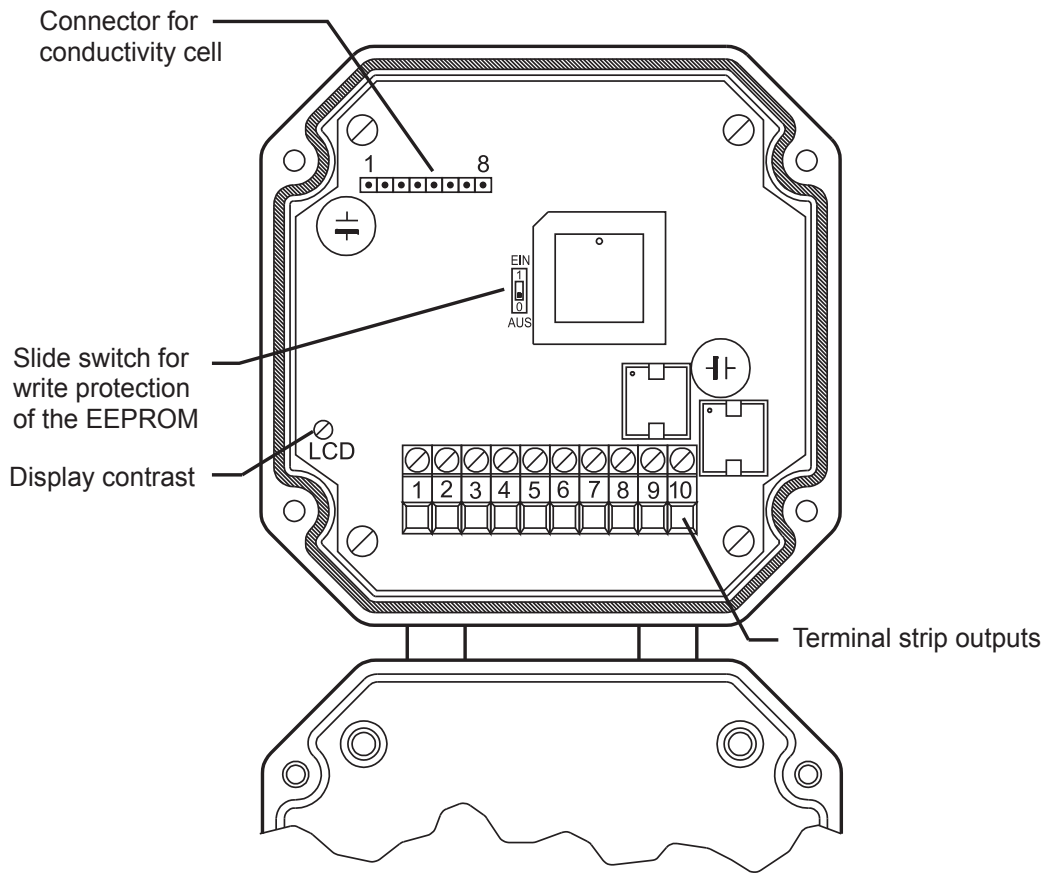

## Dimensions

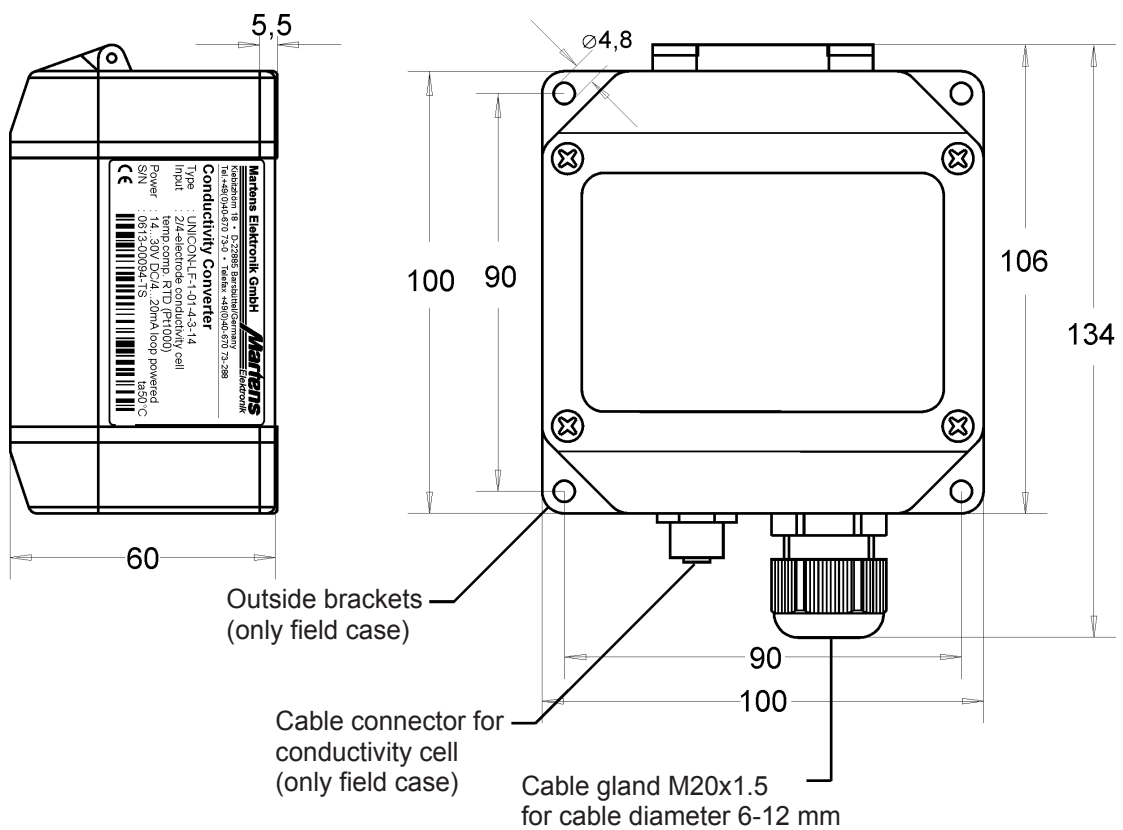

## Connection diagram

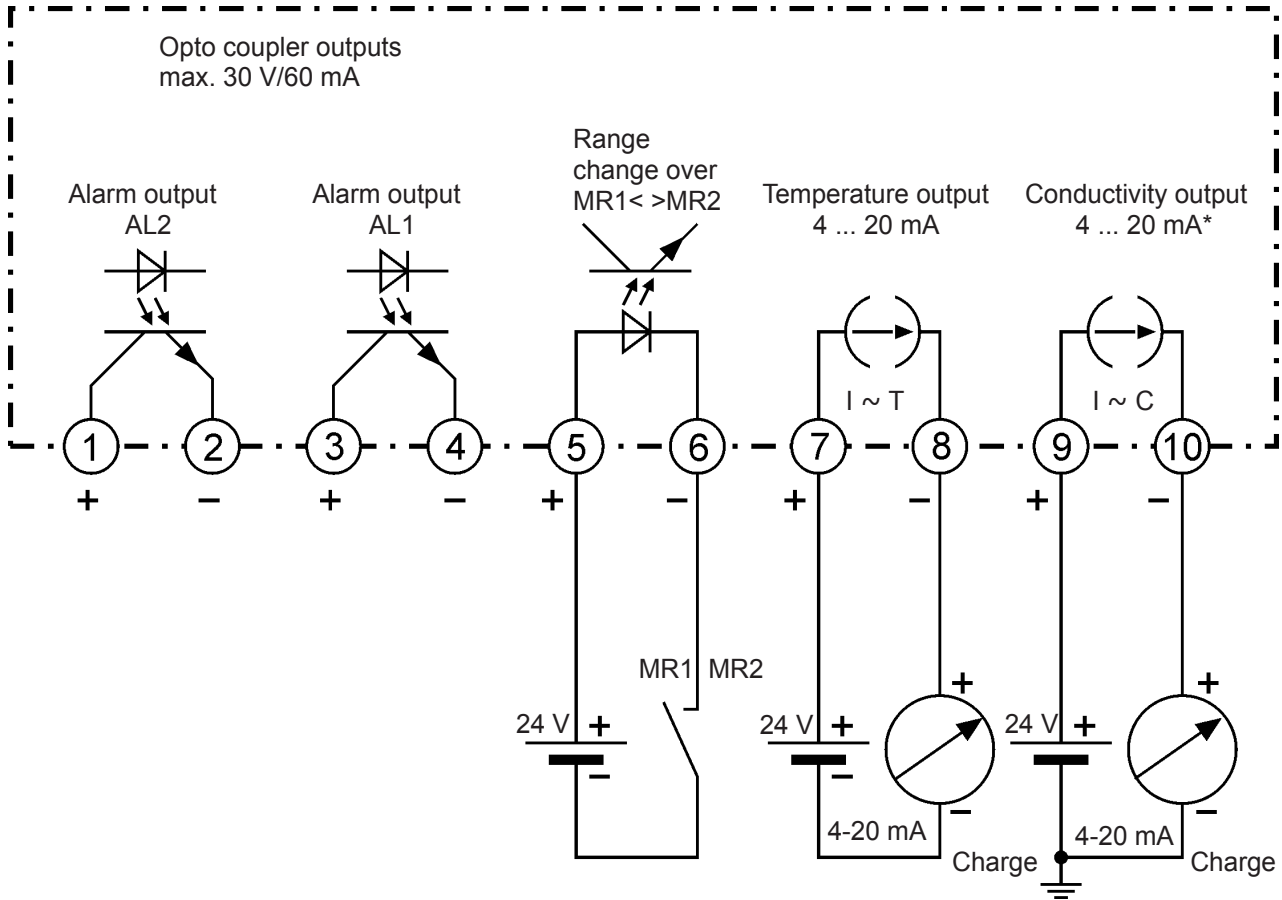

\*For supplying the converter use terminals (9) and (10) as shown. If the converter is used for monitoring only, terminals (9) and (10) must be connected direct to supply voltage.

8-pole connector plug for conductivity cell; field mounting  
(see separate data sheet or illustrated price list for connection diagram of conductivity cells).

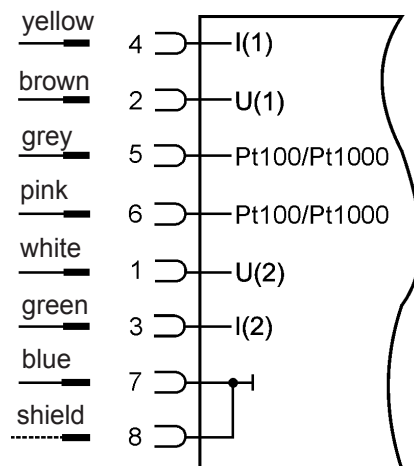



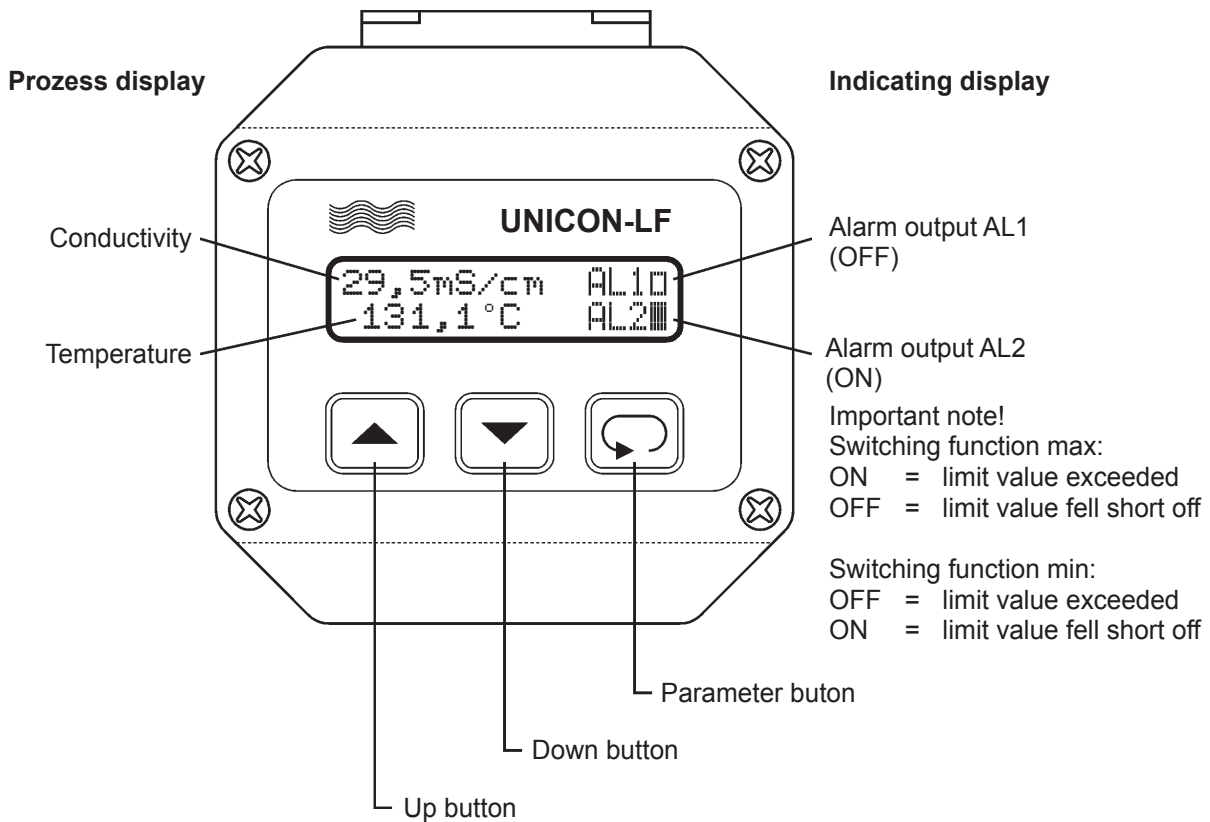

## Controls and indicators



## Description

After switching on the supply voltage, the converter initializes itself. The display shows the message about device type and software version. After the initialisation, the current measured values and the status of the alarm outputs are displayed.

The device must be configured for the intended use. The configuration level is called up by pressing the button . For selection within the parameters or for entering data, use buttons  and . Now all the parameters which defines the function of the converter can be programmed. With the last parameter, the configuration is done and the display shows the process values.

After finishing the configuration or when no button was pushed for more than 2 minutes, the program returns to the working level. Leaving the configuration level is possible at any time by pressing the button  for 2 seconds.

Option 14:

For monitoring of ultra-pure water or water for injection acc. to USP<645>, the selected alarm output must be configured as USP-alarm. The device offers a calibration routine for regularly calibration. By appropriate execution all requirements in accordance with USP<645> are fulfilled (see information on page 11).

## Programming

Notes to representation



Parameter is only displayed if configured

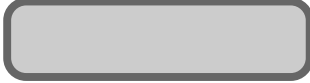

Parameter is only displayed if included (see order code)

Note to display message

Control MR+AL!

Measuring range (MR) and alarm outputs (AL) must be tested

**Note:** All parameters can be called if they are not blocked by other programmed parameters and if they are available.

### Display

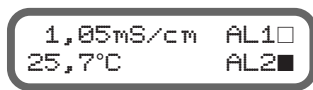

### Description

 (Factory settings are shown in the display graphic)

Process value for conductivity and temperature.  
Output indication (only if activated).  
= OFF and =ON



1



Language of the operating instructions  
Selection with buttons and .



2



This Parameter appears only at devices with option 14.  
Parameter for USP<645> calibration, see page 11  
Selection with buttons and .



With selection of calibration USP<645>, the previous values for calibration parameters are deleted.

### Configuration

3

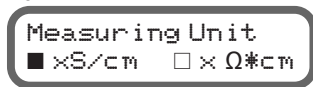

Measuring unit for conductivity or resistance.  
Selection with buttons and .



4



Conductivity measuring range 1.  
Selection with buttons and .



5



Conductivity measuring range 1, decimal point position.  
Selection with buttons and (depending on the unit).



Continue page 7

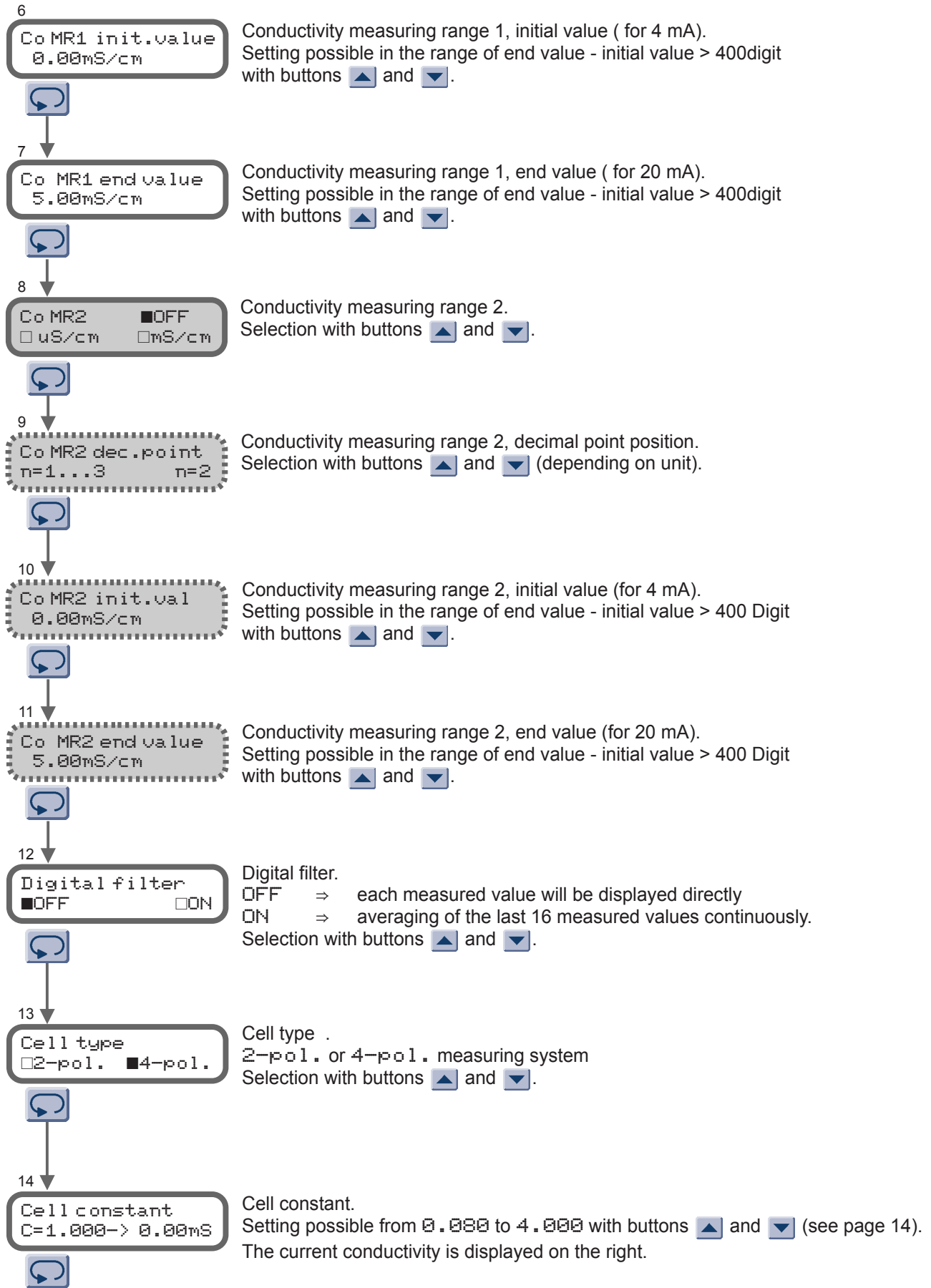

Continue page 8

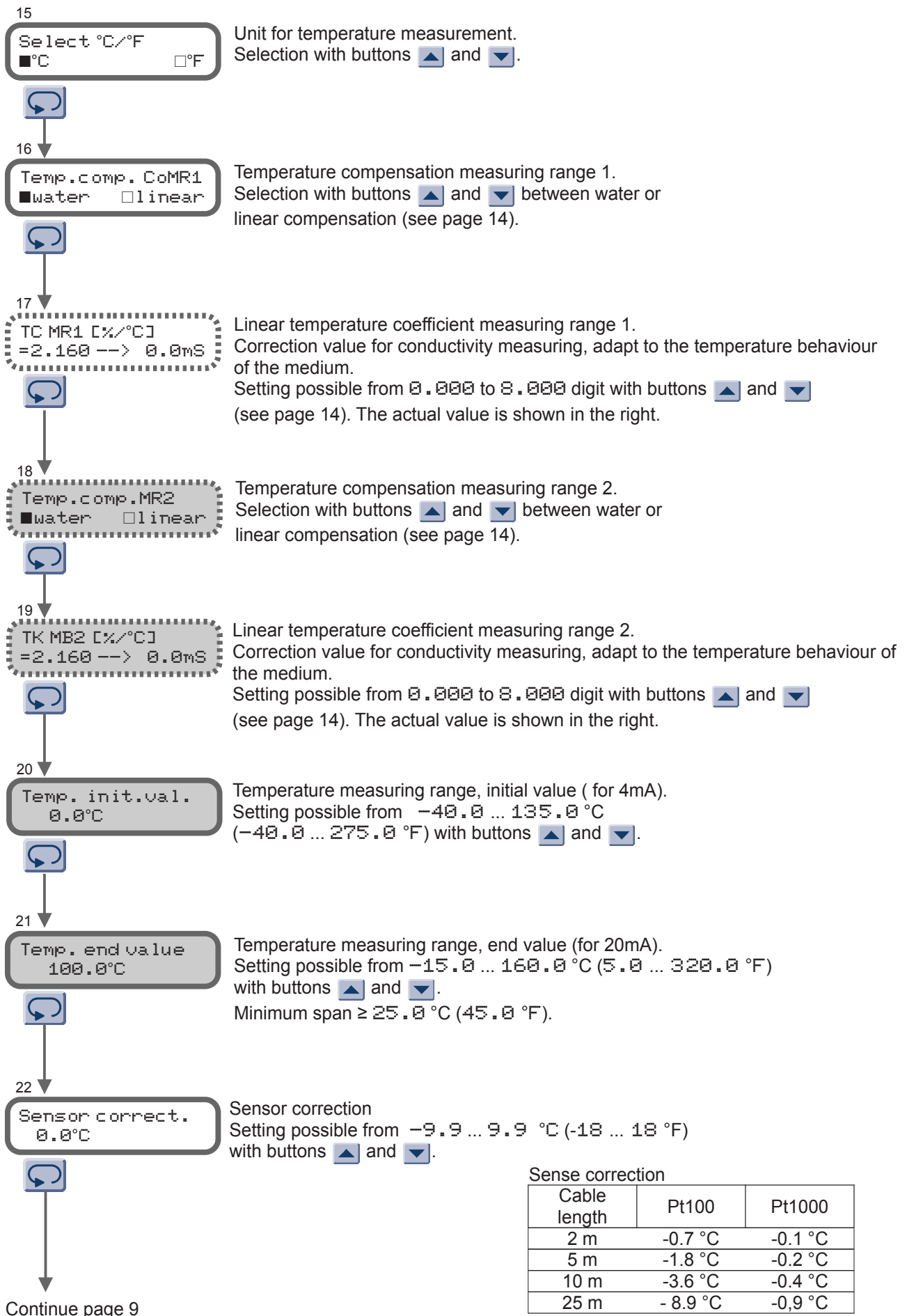



23  
 Alarm AL1  
 OFF ▼

Function alarm output AL1  
 The alarm can be switched OFF or assigned to CoMR1, CoMR2 or temperature.  
 For devices with option 14, the alarm output can also be assigned to measurement acc. to USP<645>.  
 Selection with buttons ▲ and ▼.

24  
 Alarm AL1  
 □LOW ■HIGH

Switching performance AL1  
 LOW or HIGH (if USP is selected, contact function NO or NC)  
 Selection with buttons ▲ and ▼.

25  
 Setpoint AL1  
 0.0mS/cm

Setpoint AL1  
 Setting possible in the selected measuring range with buttons ▲ and ▼.  
 (If USP is selected in range 50 ... 100 % of the limit value)

26  
 Hysteresis AL1  
 0.1mS/cm

Hysteresis AL1 (disabled at USP<645>)  
 Setting possible from 1 ... 9999 Digit with buttons ▲ and ▼.  
 (If USP is selected, the hysteresis is fixed to 0.10µS/cm)

27  
 Alarm AL2  
 OFF ▼

Function alarm output AL2  
 The alarm can be switched OFF or assigned to CoMR1, CoMR2 or temperature.  
 For devices with option 14, the alarm output can also be assigned to measurement acc. to USP<645>.  
 Selection with buttons ▲ and ▼.

Note: Function, switching performance and hysteresis for alarm output AL1 and AL2 are identical.

⚠ Simulation

During the simulation procedure, only the alarm outputs for USP<645> are fixed to their current values. For the analog outputs Co and Temp is valid: start value = process value (hold-function).

28  
 Simulation Co  
 0.0mS/cm MR1

Simulation of the conductivity (manual operation)  
 The converter works as simulator. The output current changes in range 4 ... 20 mA in accordance with the conductivity value set.  
 Setting possible in the preselected measuring range with buttons ▲ and ▼.

Continue page 10

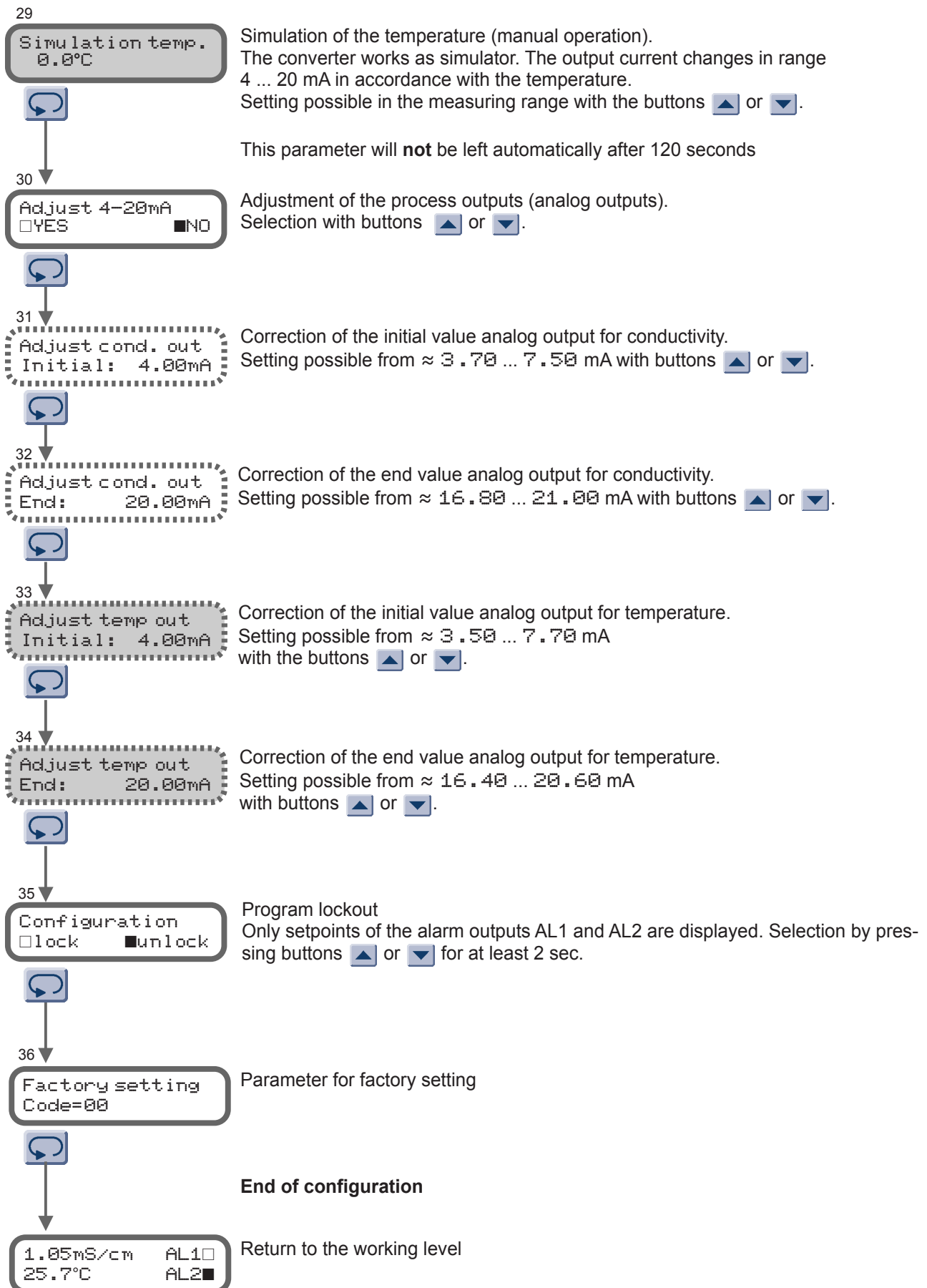

This parameter will **not** be left automatically after 120 seconds.





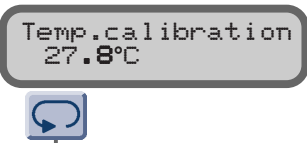

## Calibration in accordance to USP<645>

Following parameters are displayed if USP<645> calibration is selected. Operating with the following parameter assures, that the entire measuring system is calibrated.

- ⚠ After selection of parameter 2 page 6 for USP<645> calibration, the previous parameter values are deleted. During the calibration procedure the analog outputs for conductivity, temperature and the alarm outputs are fixed to their current values.  
More details see page 13.

Display	Description
37 	<b>Temp. calibration</b> Calibrate temperature measurement Immerse the ultra-pure water cell into the calibration solution (e.g. EC 23.8). Determine the temperature with a thermometer (e.g. N63802). The cell and the thermometer must be immersed at least 6cm. Wait until the measured temperature doesn't change. The determined temperature can be set with buttons ▲ or ▼. This parameter will <b>not</b> be left automatically after 120s.
38 	<b>Conductivity calibration</b> The conductivity of the calibration solution will be determined in accordance to the measured temperature (see label on the bottle of the calibration solution). The determined conductivity can be set with the buttons ▲ or ▼. This parameter will <b>not</b> be left automatically after 120s.
<b>End of &lt;USP645&gt; calibration</b>	
	Return to the process display

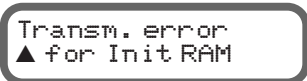
## Error messages

Display	Description
<b>Display flashes</b>	Measuring range overflow
	A changed parameter setting cannot be stored, because write protection is activated by intern slide switch in position 1. Set switch to position 0 and modify settings again
	An error occurred during data transfer between controller and EEPROM
after 2s 	Using the button ▲ a re-initialisation of the EEPROM can be stated. The programmed parameters are lost. The converter works with reduced accuracy. Please ship the converter to factory for repair service.
Reset 	The converter triggers an internal reset. An attempt is made to read data from the EEPROM.

## Conductivity measurement of ultra-pure water acc. to USP<645>

Special requirements are demanded in the pharmaceutical industry to the used ultra-pure water. The U.S. Pharmacopeia defines the limit values for conductivity in the chapter <645> for monitoring devices. These directives are acknowledged in the EU, too.

This supervising is subdivided in 3 stages. Stage 2 and stage 3 are external tests and stage 1 is an internal test and specified for cost saving and permanent monitoring of the ultra-pure water quality.

### USP<645> stage 1

According to stage 1 only the conductivity and the temperature has to be measured without temperature compensation. The limit value of the conductivity is defined in the temperature-conductivity table. For all the 5 °C steps of the temperature is one limit value valid.

### Limit table for conductivity of ultrapure water acc. to USP<645> stage 1

Temperature [°C]	Conductivity [µS/cm]	Temperature [°C]	Conductivity [µS/cm]
0.0 ... 4.9	0.6	55.0 ... 59.9	2.1
5.0 ... 9.9	0.8	60.0 ... 64.9	2.2
10.0 ... 14.9	0.9	65.0 ... 69.9	2.4
15.0 ... 19.9	1.0	70.0 ... 74.9	2.5
20.0 ... 24.9	1.1	75.0 ... 79.9	2.7
25.0 ... 29.9	1.3	80.0 ... 84.9	2.7
30.0 ... 34.9	1.4	85.0 ... 89.9	2.7
35.0 ... 39.9	1.5	90.0 ... 94.9	2.7
40.0 ... 44.9	1.7	95.0 ... 99.9	2.9
45.0 ... 49.9	1.8	≥ 100	3.1
50.0 ... 54.9	1.9		

## Requirements to a conductivity measuring system acc. to USP<645>

A conductivity measuring system must fulfill following requirements:

### Calibration

#### Conductivity-measuring device

Accuracy	±0.1 µS/cm (@ 1.3 µS/cm)
Resolution	±0.1 µS/cm
Temperature measurement	±1 °C
Temperature compensation	without
Dynamic range	10 <sup>2</sup>
Setpoint	1.3 µS/cm @ 25 °C ±0.1 µS/cm
Hysteresis	0.1 µS/cm

#### Conductivity-cell

Cell-constant	Accuracy ±2 %
Temperature sensor	not intended
Surface roughness of the electrodes	<0.8µm EHEDG-Recommendation (European Hygienic Engineering & Design Group, brussel)

All equipment and conductivity cells for measuring of ultra-pure water fulfills these requirements. For the realization of an pre-alarm the setpoints for Alarm AL1 and AL2 are programmable in the range 50 ... 100 % of the allowed limit value (acc. to table stage 1).



## Parameter settings for USP<645> measurement

For the right switching performance of the alarm output, it is only necessary to configure the wanted alarm output.

To display also the announced value in accordance with USP, the following parameter settings are required.

Parameter 3	Measuring Unit	: ■ XS/cm
Parameter 4	Co MR1	: ■ uS/cm
Parameter 5	Co MR1 dec. point	: n=2
Parameter 6	Co MR1 init.value	: 0.00uS/cm
Parameter 7	Co MR1 end value	: 30.00uS/cm
Parameter 16	Temp.-comp.Co MR1	: ■ Linear
Parameter 17	TC Co MR1 [%/C]	: 0.000

## Calibration of conductive measuring systems acc to USP<645>

Conductivity systems for ultra-pure water monitoring must be calibrated in regular time intervals. In accordance to USP<645> a calibration has to be traceable acc. to NIST (National Institute of Standards and Technology U.S.) -Measuring device- or acc. to ASTM (American Society for Testing and Materials) -conductivity cell- . All delivered measuring equipments for ultra-pure water measurement of Martens Elektronik are factory calibrated with precision resistance (feedback to NIST). The cell constant is found out with a calibration solution (feedback to ASTM) and printed on the label. This way of calibration is in accordance with the recommendation of USP<645>.

### Field calibration

For the calibration in the field the method how it is carried out before the delivery is not practicable. The calibration of the complete system is simpler and safer. We recommends the calibrating solution EC23.8 and the precision thermometer N63802 for the calibration.

If other calibrating solutions should be used, it is to consider that at pure-water measuring cells can come to a polarization effect at the electrodes if the calibrating solution has a conductivity of more than 50 µS/cm. This leads to an additional measuring error and the demand precision can not be adhered to by 2 % for certain. So such solutions should not be used.

Devices including option 14 have a special routine for USP calibration for the whole measuring-system. During the calibration procedure the analog outputs for conductivity, temperature and the alarm outputs are fixed to their current values. To be able to extend the measuring cell for the calibration, a lockable bypass must be installed

### Important information about the calibration solution EC23.8.

The calibration solution has a conductivity of 23.8 µS/cm @ 25°C and is traceable to the standard of the ASTM D-1125 Method A. Each bottle has a label with the temperature-conductivity table and the expiry date. Ideal storage conditions for a storage time of 12 month are a dark room and ambient temperature. For the calibration use clean and sufficiently big vessels. The minimum immersing depth must be at least 60 mm. Used solutions have to be wasted after the calibration (danger of soiling).

### Temperature-conductivity-table Calibration solution EC23.8

Temperature [°C]	Conductivity [µS/cm]
15	19.17
16	19.64
17	20.10
18	20.56
19	21.03
20	21.49

Temperature [°C]	Conductivity [µS/cm]
21	21.94
22	22.41
23	22.87
24	23.34
25	23.80
30	26.12

---









---

## Adjusting the cell constant

The exact cell constant C is labelled on all our conductivity cells. This cell constant must be taken into account when setting the parameter 14 (see page 7).

Due to aging processes the cell constant may be changed. In order to determine the correct cell constant the cell has to be dipped into a reference solution while carefully stirring. Various reference solutions are available. The chosen reference solution should correspond to the measurement range of the measuring system operating in.

To determine the cell constant use the following procedure:



- ① Use the button  to select parameter 16 or 18 "Temp.comp."
- ② Use the buttons  or  to select "linear"
- ③ Use the button  to select parameter 17 or 19 "TC"
- ④ Use the button  to change to "0.000"  
Press the button  for 2s, to leave the configuration level
- ⑤ Dip the conductivity cell into the reference solution
- ⑥ Determine the temperature of the solution by stirring it constantly (notice temperature shown in the display of the converter)
- ⑦ Watch the temperature / conductivity table (as indicated on the bottle of the reference solution) to determine the correct conductivity.
- ⑧ Use the button  to select parameter 14 "Cell constant"
- ⑨ Use the buttons  or  to change the parameter until the same conductivity as the reference solution will be displayed.
- ⑩ Finish adjustment and configure the parameters from item ① to ④ with the settings for the intended use.

### Temperature compensation

For accurate conductivity measurement a well matched temperature compensation is needed. The converter UNICON-LF offers two modes of temperature compensation:

**Water** Use this setting for "natural water" like ground water, spring water, above ground water and ultra-pure water. The temperature compensation will be calculated by considering the measured temperature and conductivity. The method of calculation is based on the "non-linear characteristic of natural water" according EN27888 and the electrical conductivity of ultrapure water according ASTM D11245-95 (ASTM=American Society of Testing and Materials). In the temperature range from 0 °C to 100 °C good results are effected.

**Linear** Use this setting for saline solution, dilute acid, caustic solution and cleansing solution. This solution will be compensated by using a "linear characteristic". By factory setting the temperature coefficient is set to compensate a NaCl solution. Other solutions needs a special TC. Use the data sheet of the suppliers to define the TC. If there is no information about the TC available, use following procedure:

- ① Dip the conductivity cell into the solution
- ② Stir the solution constantly and heat it to a temperature of 25 °C (watch temperature on the display)
- ③ Notice the measured conductivity at 25 °C
- ④ Heat the solution to the working temperature (minimum difference 10 °C)
- ⑤ Use button  to select "TC" parameter.
- ⑥ Use the buttons  or  to change the parameter until the displayed conductivity is the same as shown at 25 °C

If there is no way to use this procedure, following values can be used approximately:

NaCl-solution	(20% weight of electrolyte)	2.160%/°C (factory setting)
NaOH-solution	(20% weight of electrolyte)	2.990%/°C
KOH-solution	(20% weight of electrolyte)	1.980%/°C
H <sub>3</sub> PO <sub>4</sub> -solution	(20% weight of electrolyte)	1.140%/°C
H <sub>2</sub> SO <sub>4</sub> -solution	(20% weight of electrolyte)	1.450%/°C
NH <sub>4</sub> NO <sub>3</sub> -solution	(20% weight of electrolyte)	1.790%/°C

## Installation notes

When installing conductivity cells, please make sure, that there is no air at the active area of the conductivity cell.

When installing a system with UNICON-LF head mounting, it may be necessary to turn converter and conductivity cell against each other for easy operation and better reading of the display. These assembly variations are possible in steps of 30°.

In order to turn the case against the cell, please proceed as follows:

- ① Open the UNICON-LF by releasing the 4 cover screws
- ② Release the nut of the connected UNICON-LF and conductivity cell appr. 2 revolutions.

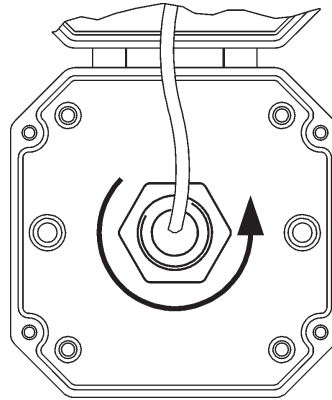

- ③ Separate UNICON-LF and conductivity cell and place in the desired angle with the turning lock into the case.

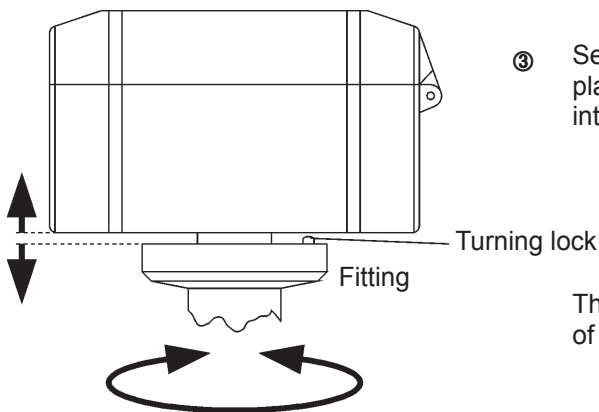

These assembly variations are possible in steps of 30°.

- ④ Tighten the Lock nut and Armature of the UNICON-LF.

### Notes to the Mounting positions. (valid for Mounting mode 01 and 02)

Mounting types for Position 1 are 2 are allowed.

Position 3 is not necessary, because water drops can go across the pressure compensation membrane. By cleaning the device with high pressure cleaner, humidity can go inside the case, also.



## Ordering code:

UNICON-LF -  1. -  2. -  3. -  4. -  5.

### 1. Model

- 1 Output 4 ... 20 mA for conductivity, loop powered, 2 voltage free transistor alarm outputs, supply voltage 14 ... 30 V DC
- 2 as 1, but additional 2. measuring range for conductivity and output 4 ... 20 mA for temperature, loop powered

### 2. Mounting

- 01 Head mounting  
Mounting directly on the UNICON-LF with flat cable connector of the cell
- 02 Field mounting, connection with separate connection cable,
- 03 as 02, but plugs stainless steel 1.4571  
**Note:** Conductivity cell and connection cable must be ordered separately (see data sheet about accessories and illustrated pricelist)

### 3. Measuring principle

- 4 4-electrode measurement (2-electrode cell connectable)

### 4. Temperature measurement (RTD)

- 1 Pt100 sensor
- 3 Pt1000 Sensor

### 5. Options

- 00 without option
- 14 Measurement and monitoring accc. to USP<645>(USP23)

For more informationen about pH- and ORP-measuring systems

- 2- and 4-electrode cells
- Ultra pure water cells
- Inline fittings
- Accessories for conductivity measuring systems

please on request.